

PRESSURE REDUCING VALVE RP16

DESCRIPTION

The ADCA RP16G series pressure reducing valves are self-actuated direct action proportional action type, operating without auxiliary energy, designed for use on steam, compressed air, industrial inert gases and liquids compatible with the construction.

They are suitable for reducing steam pressure in all energy and process systems where pressures should be kept constant.

Connections are flanged.

OPERATION

Pressure reduction is achieved by means of variable throttling of the inlet flow at the valve seat by variation of the flow area between seat and disc. The outlet pressure which is transmitted through the feed-back line to the diaphragm chamber counteracts the spring force acting on the valve spindle and controls the valve aperture corresponding to the spring setting and thus to the required outlet pressure.

MAIN FEATURES

Simple and robust construction

OPTIONS:

Nitrile rubber soft seated version for air and gas applications where tight shut-off is required.

USE:

Saturated steam, compressed air and other gases and liquids compatible with the construction.

AVAILABLE

MODELS:

RP16G and RP16GN – PN16 cast iron
Suffix N : soft seated with nitrile rubber

SIZES:

DN 15 to DN 50

CONNECTIONS:

RP16G Flanged EN 1092-2

INSTALLATION:

Horizontal installation.

An "Y" strainer , steam separator and steam trap should be provided upstream the valve.

See IMI, installation and maintenance instructions.



CE MARKING (PED-European Directive 97/23/EC)	
PN 16	Category
DN15 to DN50	SEP - art. 3, paragraph3

LIMITING CONDITIONS		
	RP16G Cast iron	RP16GN * Cast iron
Body design conditions	PN16	PN16
Max.upstream pressure	13 bar	13 bar
Max.downstream pressure	13 bar	13 bar
Min.downstream pressure	0,5 bar	0,5 bar
Max.operating temperature	200°C	90°C
Max.reducing ratio	5:1	5:1
Max.cold hydraulic test	24 bar	24 bar
Max.hydraulic factory valve body test	24 bar	24 bar

Suffix N : - a maximum turndown ratio 10:1 should be observed.PTFE can also be offered.

DIMENSIONS (mm)						
VALVE			ACTUATOR			
SIZE DN	A	B	WGT. Kgs	TYPE	C	WGT. Kgs
15	130	440	12,7	A1	172	4,3
20	150	440	12,7	A11	172	4,3
25	160	440	13,7	A2	220	7,3
32	180	445	15,7	A21	220	7,3
40	200	445	17,7	A3	282	11,3
50	230	540	25,7	A4	340	16,3

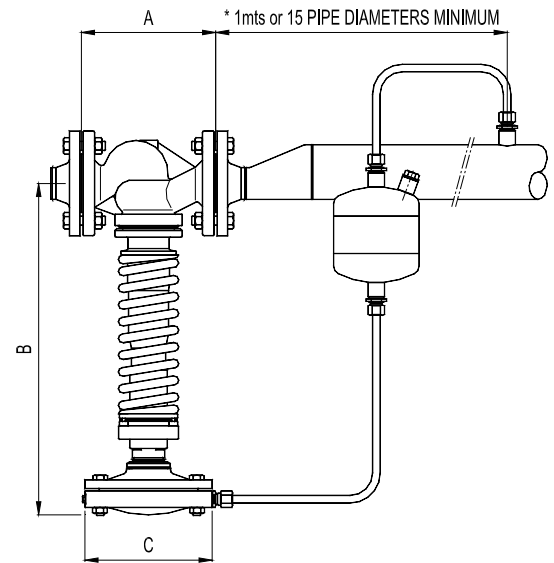

MATERIALS		
POS.	DESIGNATION	MATERIAL
1	Valve body (PN16)	GJS-400-18LT / 0.7043
2	Piston body	GJS-400-15 / 0.7040
3	Valve seat	HARDENED ST. STEEL
4	* Valve disc	HARDENED ST. STEEL
4	* Soft valve disc	AISI 304 / 1.4301 ; NBR
5	Guide	AISI 304 / 1.4301
6	* O-Rings	NBR
7	* Diaphragm chamber	GJL-250 / 0.6025
8	Spindle	AISI 304 / 1.4301
9	Regulating spring	SPRING STEEL
10	* Impulse line	COPPER
11	* Condensate vessel a)	S235JRG2 / 1.0038

* Available spare parts.

a) Not necessary when in operation with low temperature compressed air or water.

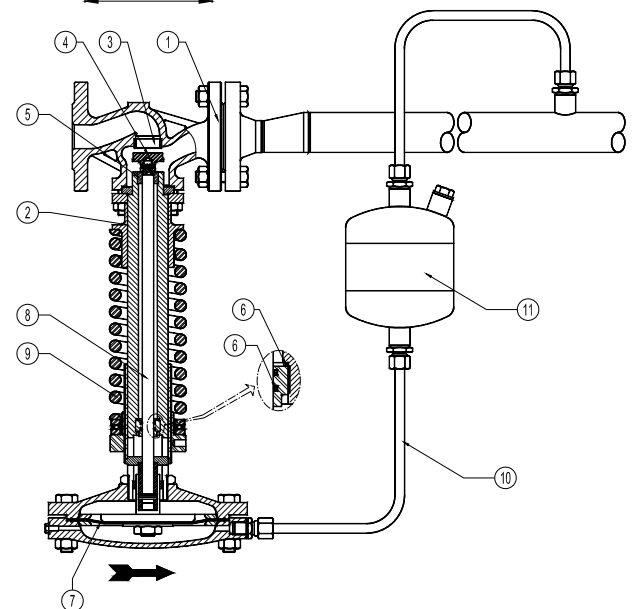

ACTUATOR AND SPRING SELECTION TABLE								
VALVE SIZE DN	Kvs m3/h		ACTUATOR					
			A-4	A-3	A-2	A-21	A-1	A-11
15	3,8	Outlet (bar)	0,5 - 0,99	1,0 - 1,6	1,7 - 3,8	3,9 - 5,5	5,6 - 8,2	8,3 - 13
		Spring Nº.	60	60	60	60	60	60
20	5,1	Outlet (bar)	0,5 - 0,99	1,0 - 1,6	1,7 - 3,8	3,9 - 5,5	5,6 - 8,2	8,3 - 13
		Spring Nº.	60	60	60	60	60	60
25	9,1	Outlet (bar)	0,5 - 0,99	1,0 - 1,6	1,7 - 3,8	3,9 - 5,5	5,6 - 8,2	8,3 - 13
		Spring Nº.	60	60	60	60	60	60
32	11,8	Outlet (bar)	0,5 - 0,99	1,0 - 1,6	1,7 - 3,8	3,9 - 5,5	5,6 - 8,2	8,3 - 13
		Spring Nº.	60	60	60	60	60	60
40	14,4	Outlet (bar)	0,5 - 0,99	1,0 - 1,6	1,7 - 3,8	3,9 - 5,5	5,6 - 8,2	8,3 - 13
		Spring Nº.	60	60	60	60	60	60
50	26,5	Outlet (bar)	0,5 - 0,99	1,0 - 1,9	2,0 - 4,2	4,3 - 6,9	7 - 8,5	8,6 - 13
		Spring Nº.	61	61	61	61	64	64

HOW TO SIZE (using Kvs) : please consult formulas on IS PV10.00 E or consult factory.

Typical Installation

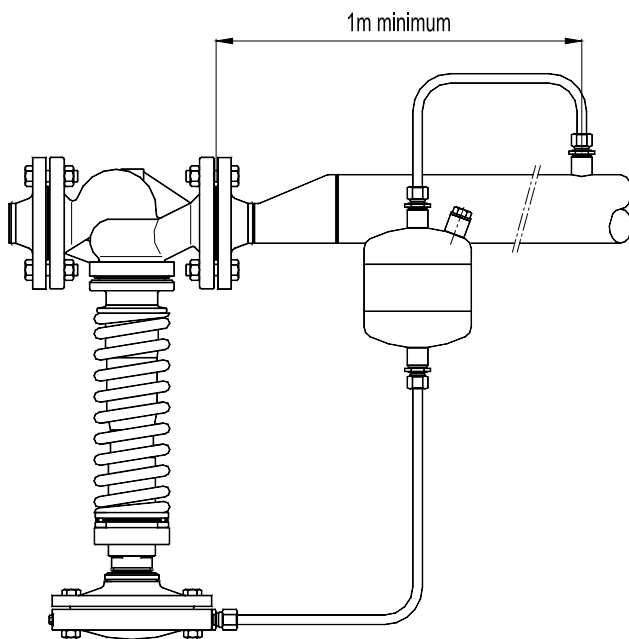
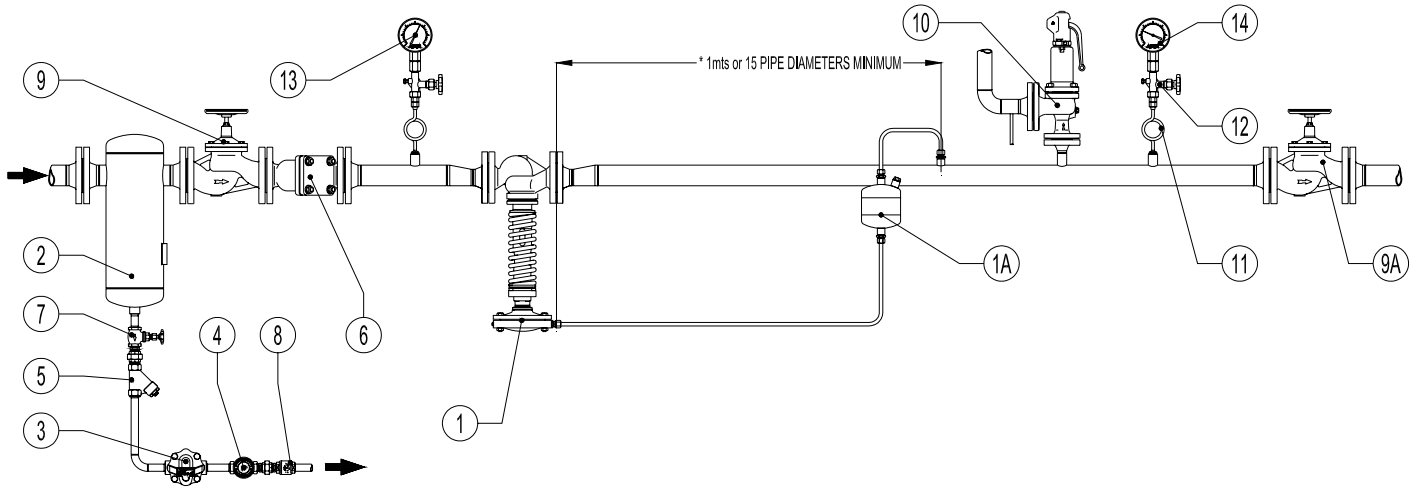

MATERIALS		
POS.	DESIGNATION	MODEL
1	Pressure reducing valve	ADCA RP16G
1A	Water seal pot	POP
2	Humidity separator	ADCA S 25
3	Steam trap	ADCA FLT series
4	Sigh glass	ADCA SW 12
5	Y Strainer	ADCA IS 16
6	Y Strainer	ADCA IS16F
7	Stop valve	ADCA GV32B
8	Check valve	ADCA RT
9	Stop valve	ADCA VF16
9A	Stop valve	ADCA VF16
10	Safety valve	-
11	Coil	ADCA GSC-40
12	Gauge cock	ADCA GC-400
13	Upstream pressure gauge	ADCA MAN-100
14	Downstream pressure gauge	ADCA MAN-100

Remarks :

By-pass : if overpressure can not be accepted the use of by-pass is not recommended. In alternative, for critical process, two pressure reducing stations should be installed in parallel.

PN ratings and materials according to the operating pressures.

* The balance pipe connection is recommended to enter downstream pipe at a minimum of 1 meter from valve.

Installation instructions are available (IMI-RP16) and typical assembling drawing.

Special assembling designs may be produced on request.